



Applications of Thermal Energy Storage for Grid Electric Storage

Dr. Zhiwen Ma, Patrick Davenport
National Renewable Energy Laboratory (NREL)
Presentation to International Workshop on Carnot Batteries
September 15, 2020



Outline

- About Particle Thermal Energy Storage (TES)
- NREL **ENDURING** Project for Long Duration Energy Storage (LDES)
- Economic Analysis and Commercialization Pathway:
 - An example of repurposing a coal plant
 - Cost sensitivity analysis

Thermal Energy Storage for Carbon Free Energy

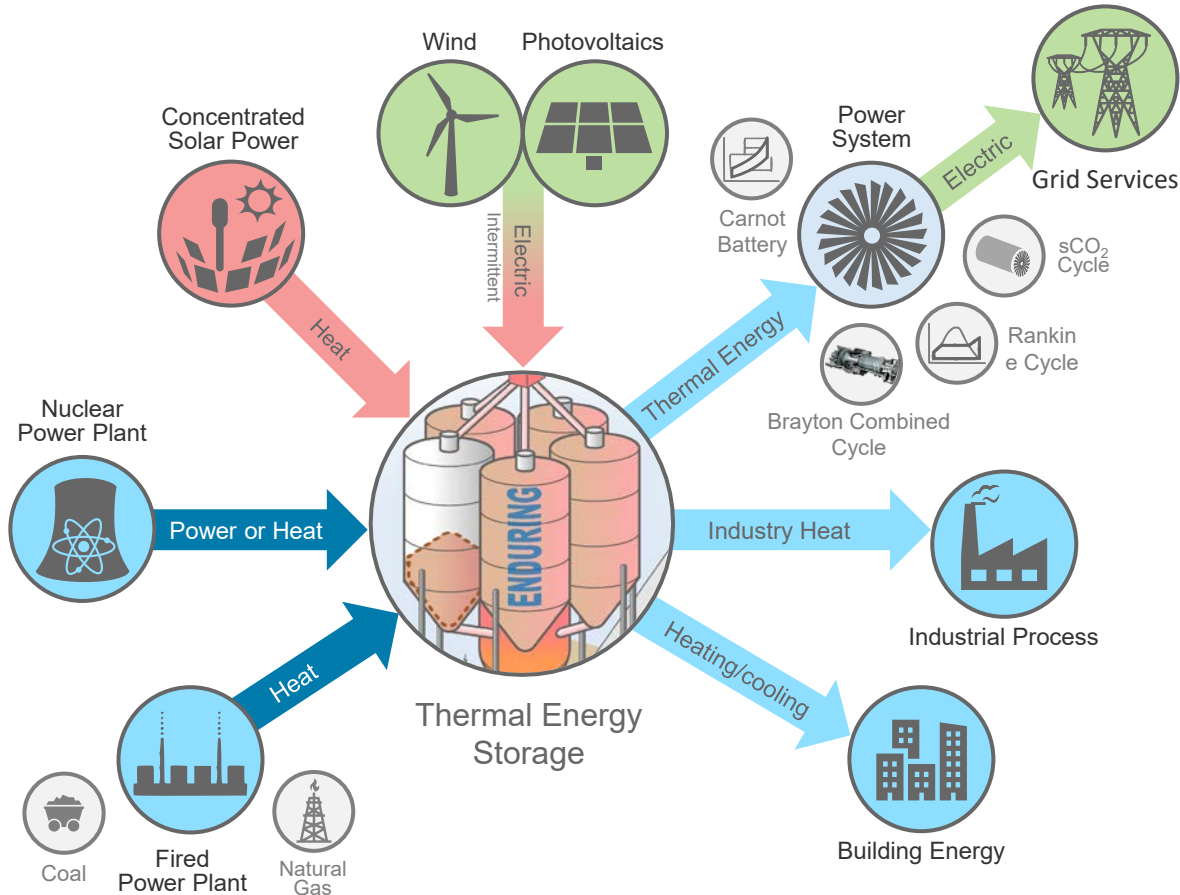

- Thermal Energy Storage (TES) has potentials in supporting energy storage for power generation, industry processes, building heating and cooling.
- The broad temperature range of solid particles (no freeze and stable at $>1000^{\circ}\text{C}$) can support full spectrum of TES needs.

Thermal Energy Storage and Media Selection

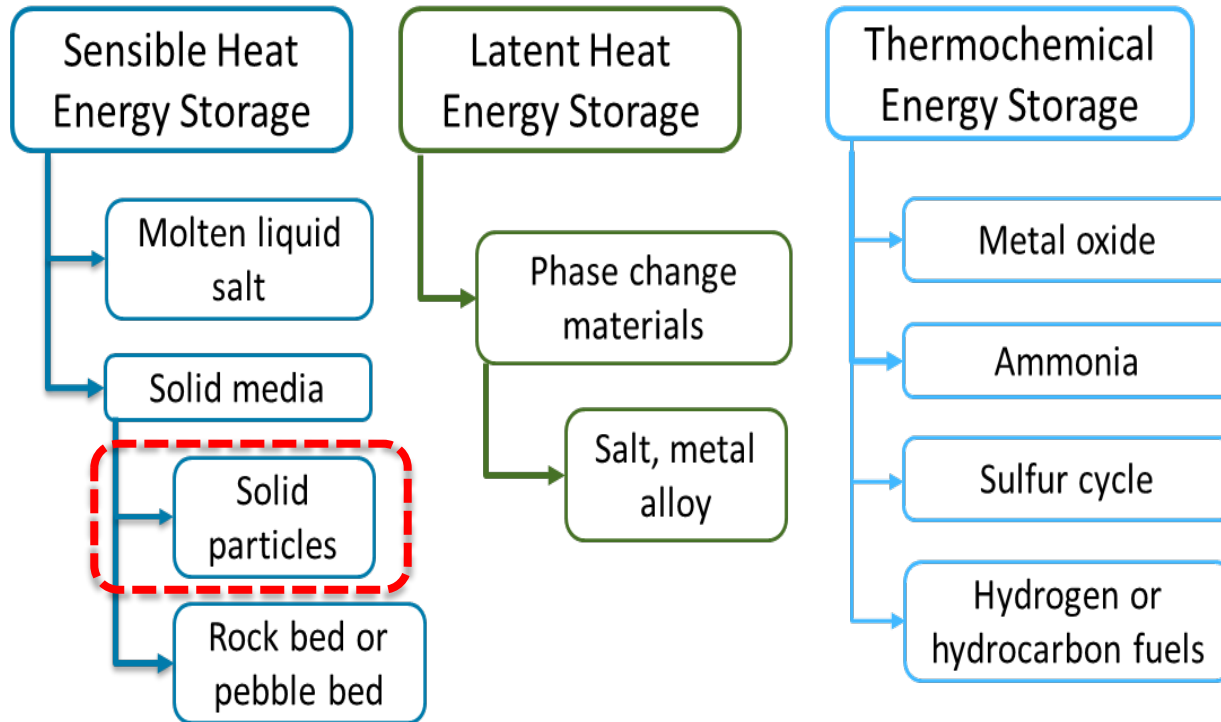

Particle TES has several advantages over current Carnot Battery (CB) using molten-salt storage: high temperature capability, no freeze, storing both hot and cold energy, direct contact heat exchanger, low cost.



Silica sand was selected in the ENDURING system for its abundance, low cost (30-40\$/ton), high stability tested.

Integration with Steam Rankine Cycle

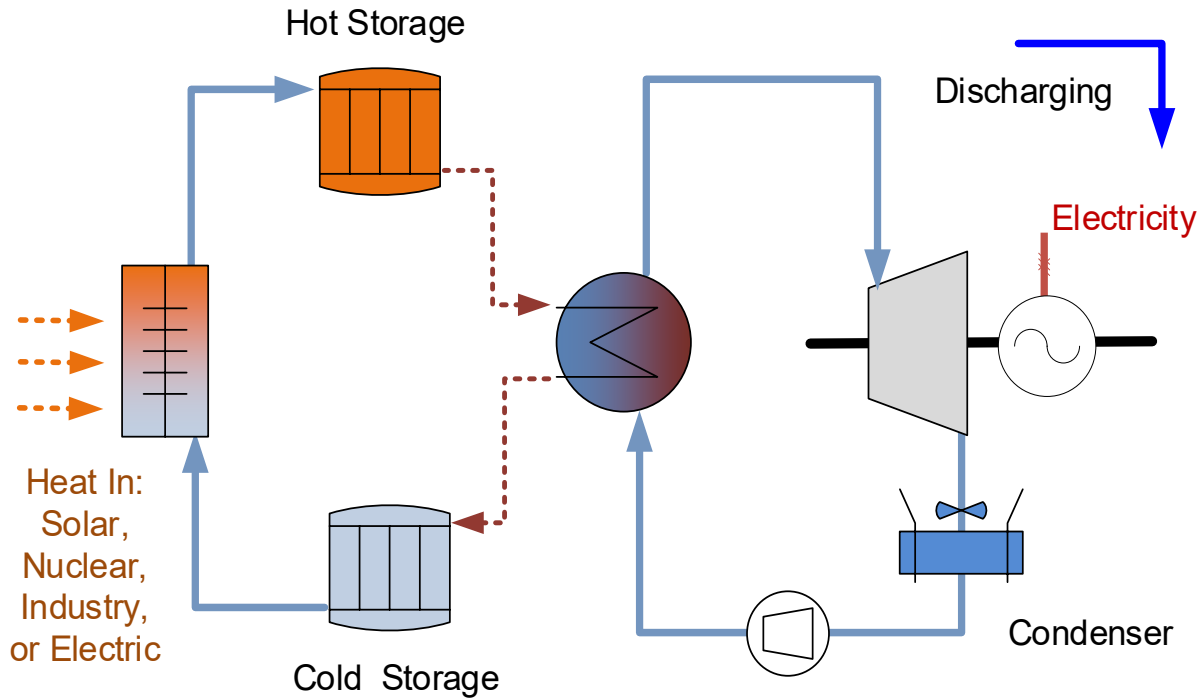

■ Pros:

- Low capital investment
- Able to converting coal plants to energy storage as new revenue source.
- Low technology and financial risks and quick market entry

■ Cons:

- Low power cycle efficiency
- Slow ramping and load following

Integration with Brayton Combined Cycle

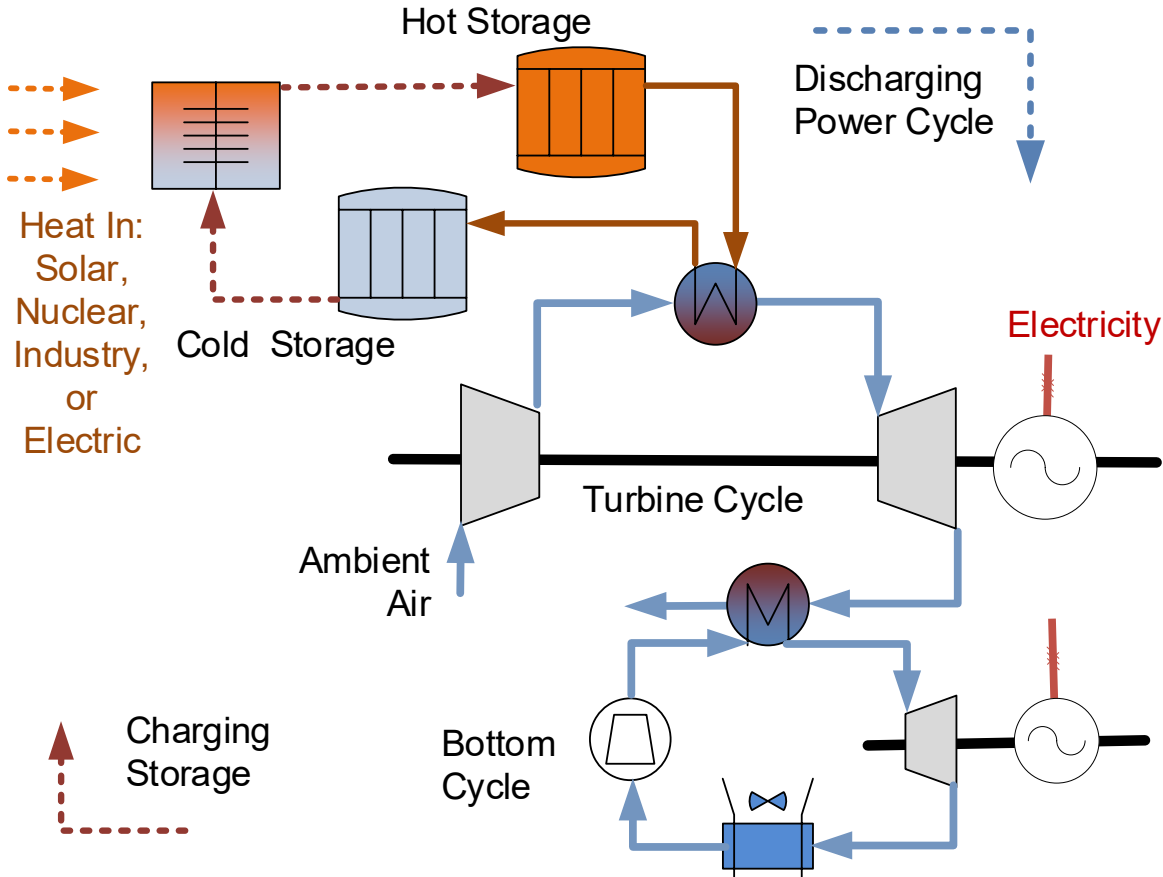

■ Pros:

- Adapted from a commercially available gas-turbine combined cycle (GTCC) power system.
- Large temperature difference creates high energy storage density.
- Converting from a GTCC plant reduces capital cost significantly.

■ Cons:

- High efficiency relies on high turbine operation and TES temperatures.

Integration with a Carnot Battery

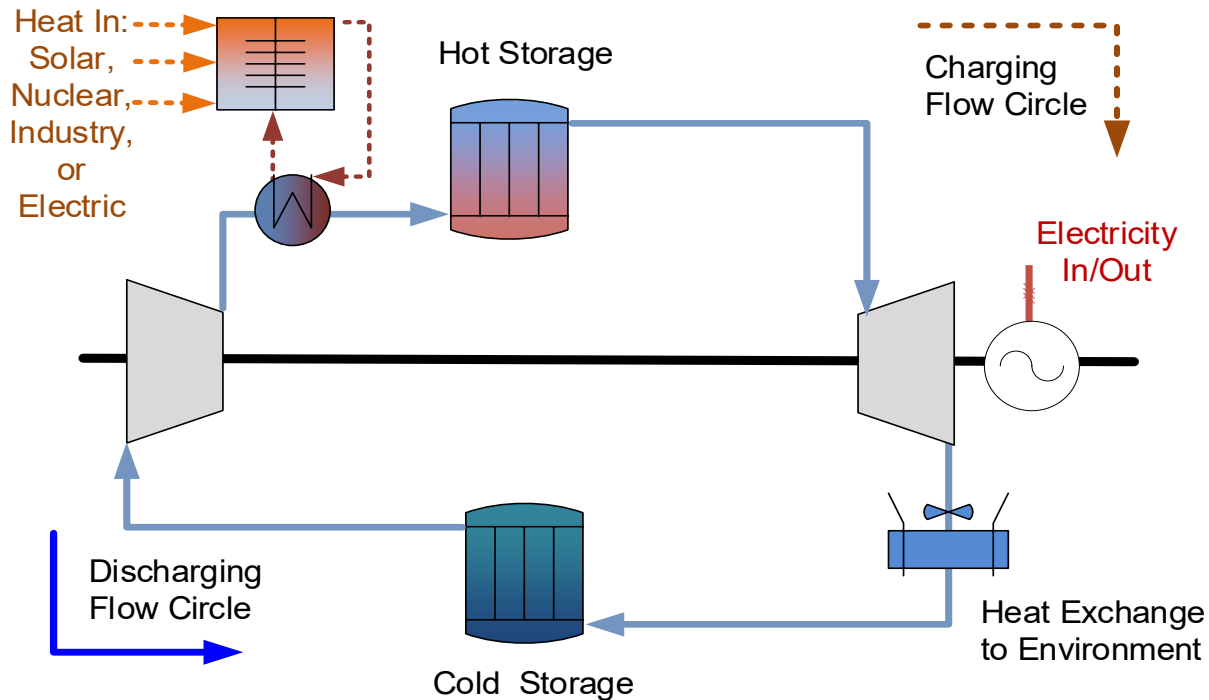

Pros:

- Achieving high roundtrip efficiency
- Charging/discharging may use same turbomachinery and lower system cost.
- Seamless integration with the ENDURING particle TES technology.

Cons:

- CB Technologies are under development and to be demonstrated
- System and turbomachinery needs scale up for deployment.

Configuration of Pumped Heat Electricity Energy Storage (PHES)

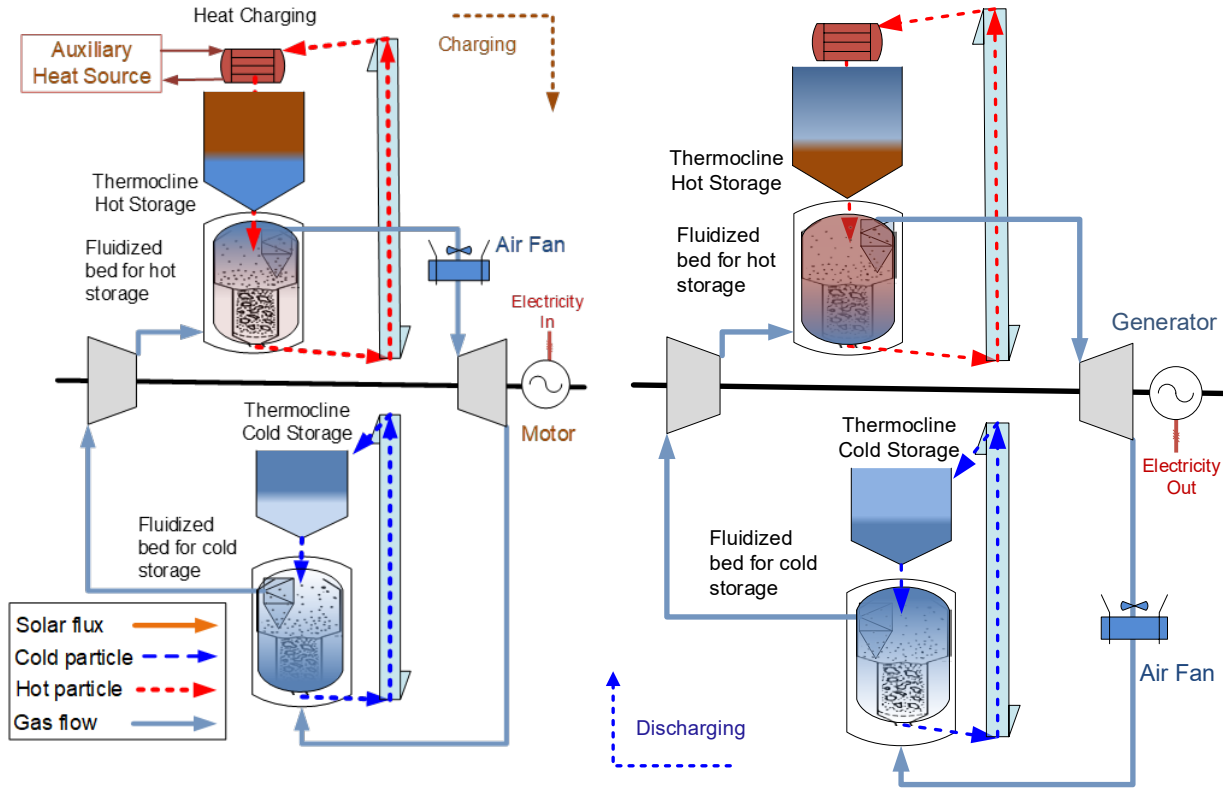

- Economically and efficiently store both cold and hot thermal energy in particles (cost 35\$/ton, from -200°C to >1000°C).
- Direct gas/particle contact in heat exchanger (HX) avoids heat transfer surfaces and minimizes the exergy loss and HX cost.
- Integrate with grid energy storage for flexible power generation.

PHES can achieve high roundtrip efficiency for electricity storage.

Economic Long-Duration Electricity Storage by Using Low-Cost Thermal Energy Storage and High-Efficiency Power Cycle (ENDURING)

Funded under ARPA-E DAYS Program

U.S. Department of Energy (DOE)

3-year | \$2.79M DOE funding (\$443K cost share)

- About Particle Thermal Energy Storage
- NREL **ENDURING** Project for Long Duration Energy Storage (LDES)
- Economic Analysis and Commercialization Pathway:
 - An example of repurposing a coal plant
 - Cost sensitivity analysis

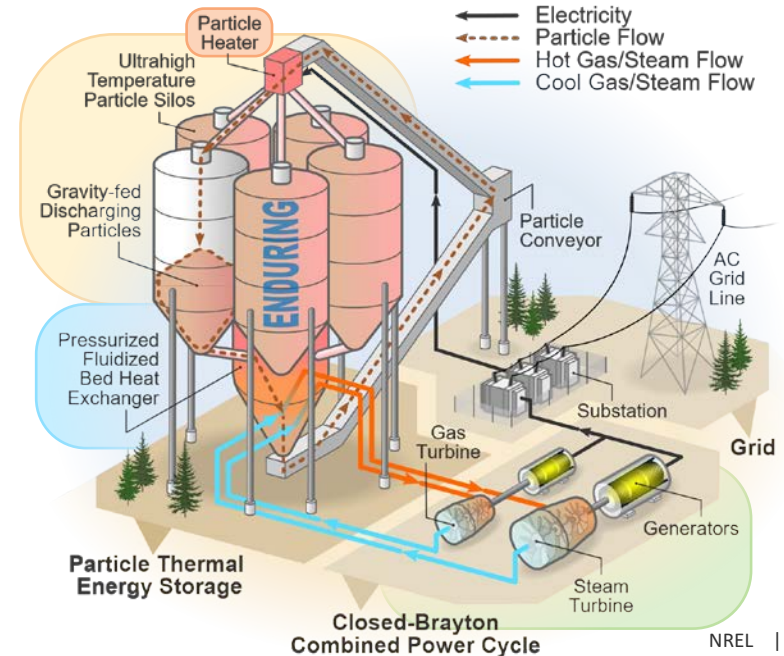

ENDURING Energy Storage System

ENDURING LDES operates as a thermal battery, in a large scale.

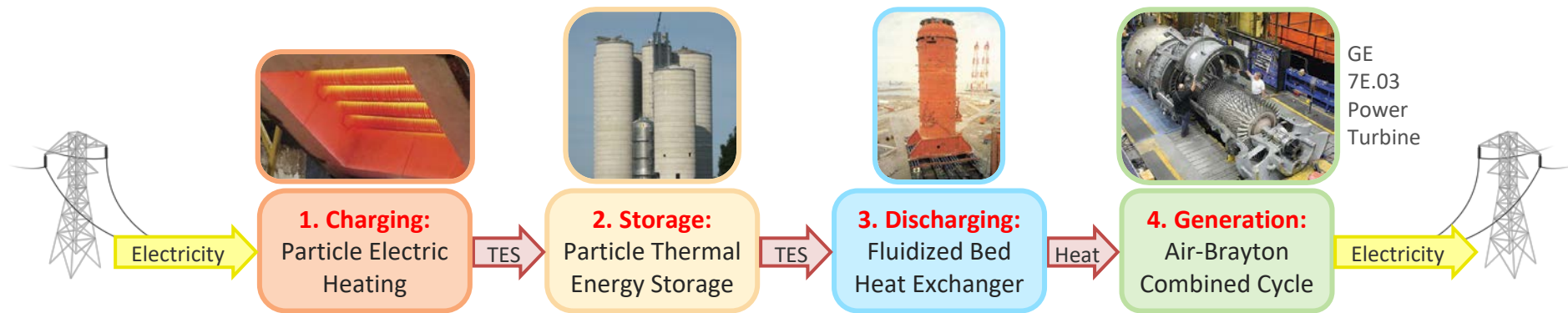

- Aim at 10-100 hours of storage, 50 - 400 MWe (scalable).
- Increased cycle efficiency with ultrahigh temperature (1,200°C) particle TES.
- Novel fluidized bed heat exchanger with gas/particle direct contact.
- Low-cost storage offers site flexibility and broad applications.
- Leverage potential assets from retired thermal power plants.

Storage Media Thermal Stability Tests

500-hour heating test at 1,200°C in air, air with 50% humidity, and nitrogen

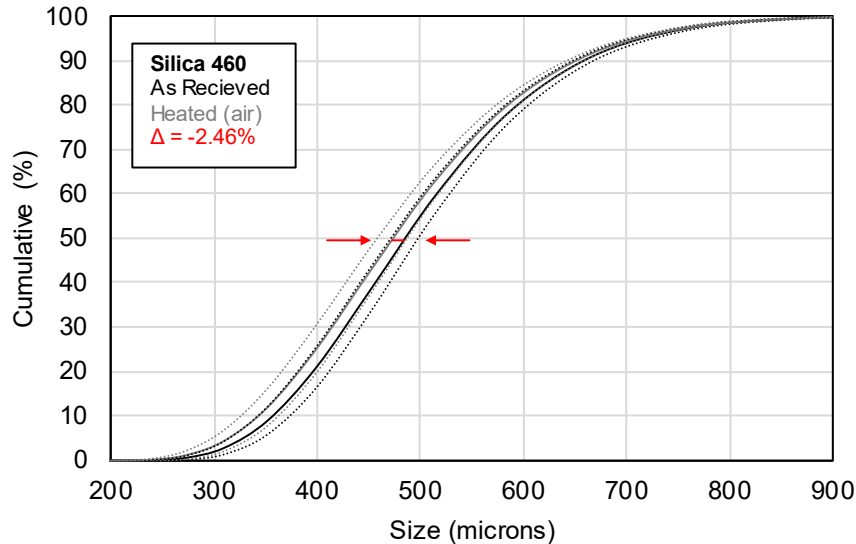

Performed 100 cycles between 300°C and 1,200°C

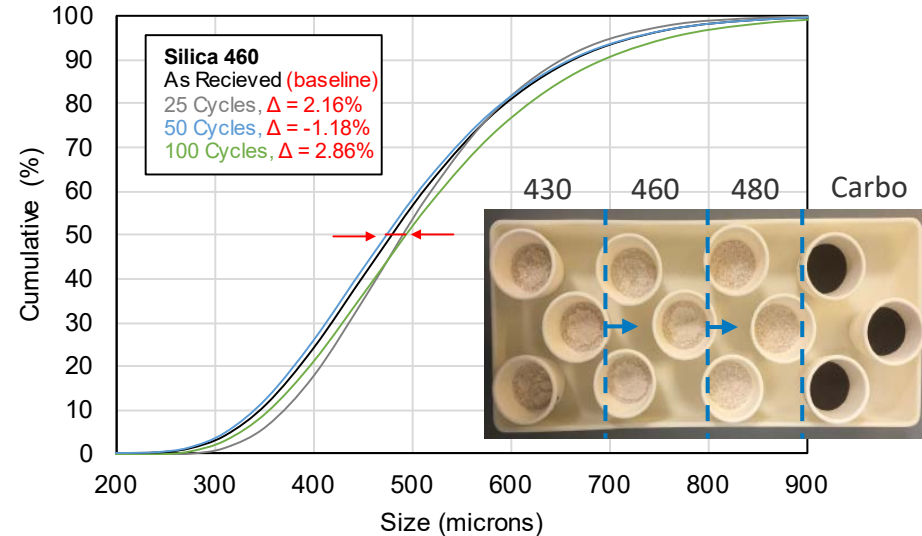

Particle size distribution changes of silica sand are small after the thermal tests.

Material stability and compatibility tests proved storage media and insulation.

Particle Thermal ENERGY Storage (TES)

- Screened and tested five storage particle candidates and three insulation materials.
- Tested the compatibility between storage media and insulation materials at 1200°C.
- Designed particle TES for ENDURING energy storage: 1) low cost storage media (30–40\$/ton silica sand), 2) containment (concrete silo, insulation), 3) particle transport and handling.
- Storage cost about 2\$/kWht (depending on charging/discharging temperatures), a fraction of molten-salt or battery storage.



Material thermal stability/compatibility tests at 1200°C

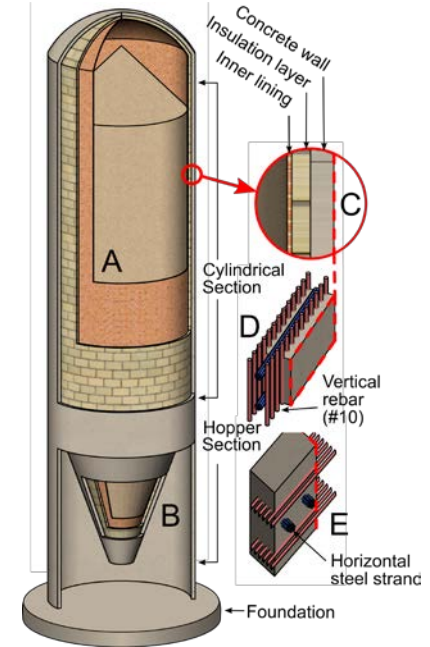

Particle TES up to 7 GWht per silo

Air/Particle Fluidized Bed Heat Exchanger (FB-HX)

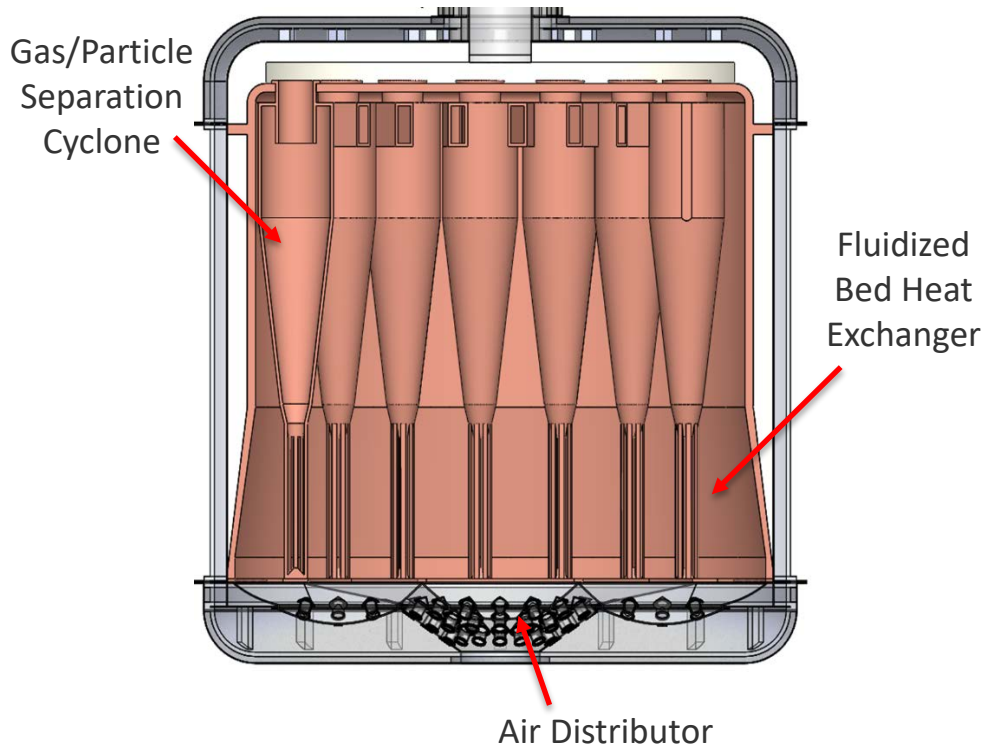

- Support all types of thermal power cycles.
- Minimize exergy loss and avoid heat transfer surface for direct gas/particle heat exchanger.
- Leverage commercial fluidized bed boiler experiences.
- Cost about \$80/kW using low cost materials and readily available fabrication methods.

Preliminary design and analysis show feasibility of the FB-HX design.

Full Scale Module – a 135 MWe, 26 GWht Storage

ENDURING TES key parts:

- 1 Particle transport
- 2 Charging heater
- 3 Particle TES
- 4 Particle dispenser
- 5 FB-HX
- 6 Air pipes
- 7 Power system

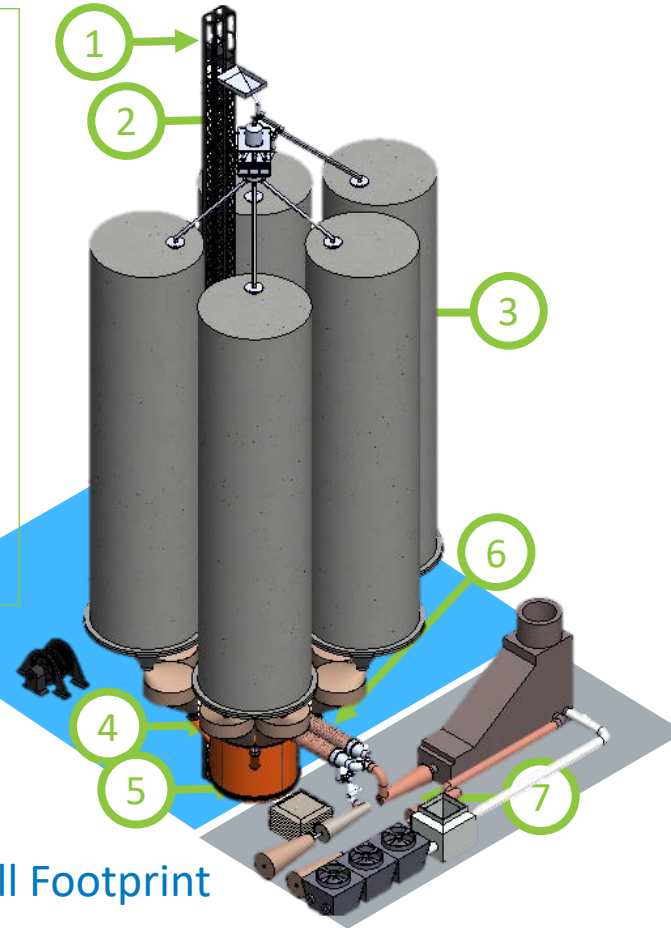

Modular Design,
Site Flexibility, and Small Footprint

- Developed modeling tool for sizing the component and calculating heat/mass balance.
- Evaluated component performance and cost with model analysis.
- Per module footprint 1.34 acre (66.5 m X 81.5 m).
- ENDURING TES is scalable and supports various power systems.

Outline

- About Particle Thermal Energy Storage (TES)
- NREL **ENDURING** Project for Long Duration Energy Storage (LDES)
- Economic Analysis and Commercialization Pathway:
 - An example of repurposing a coal plant
 - Cost sensitivity analysis

Market Entry: Repurpose Thermal Power Plants

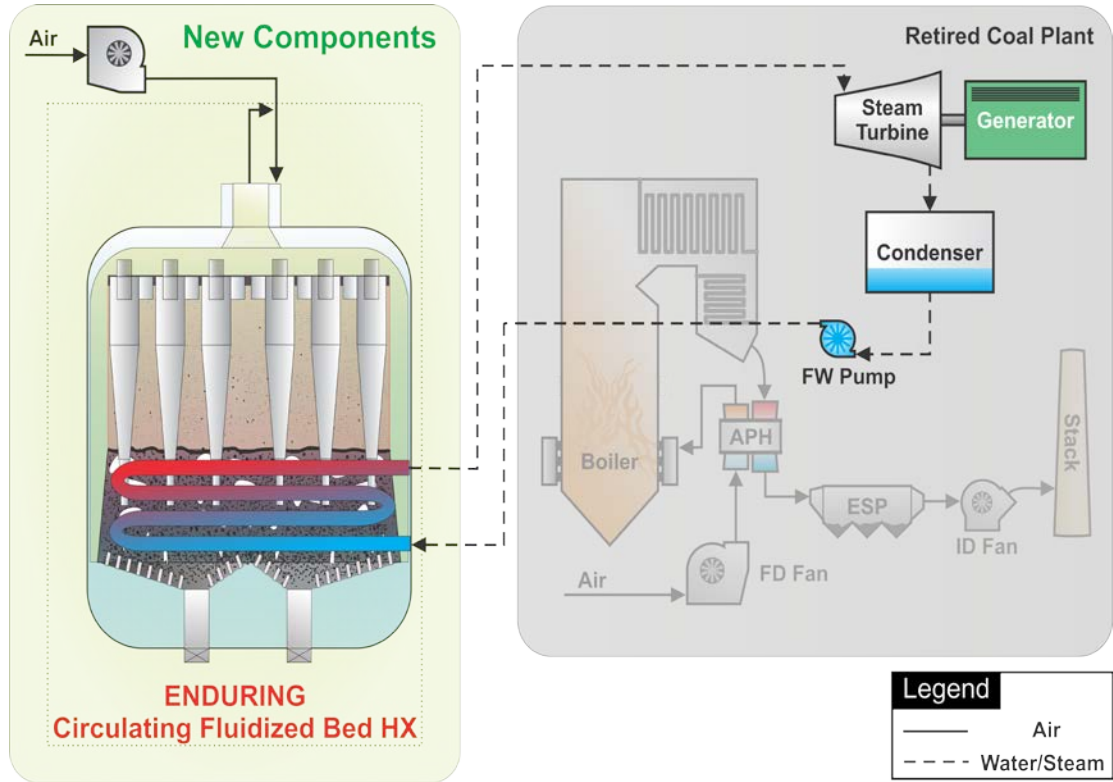

- Leveraging an existing infrastructure and power system can dramatically reduce the capital cost and earn revenue for a thermal power plant.
- Siting on an existing plant avoids permit and transmission cost and benefits the local community.

An example of repurposing a coal power plant, while repurposing a gas plant is same to an ENDURING system.

Economic Analysis of the Storage Cost

Levelized cost of storage (LCOS) as used in ARPA-E DAYS program:

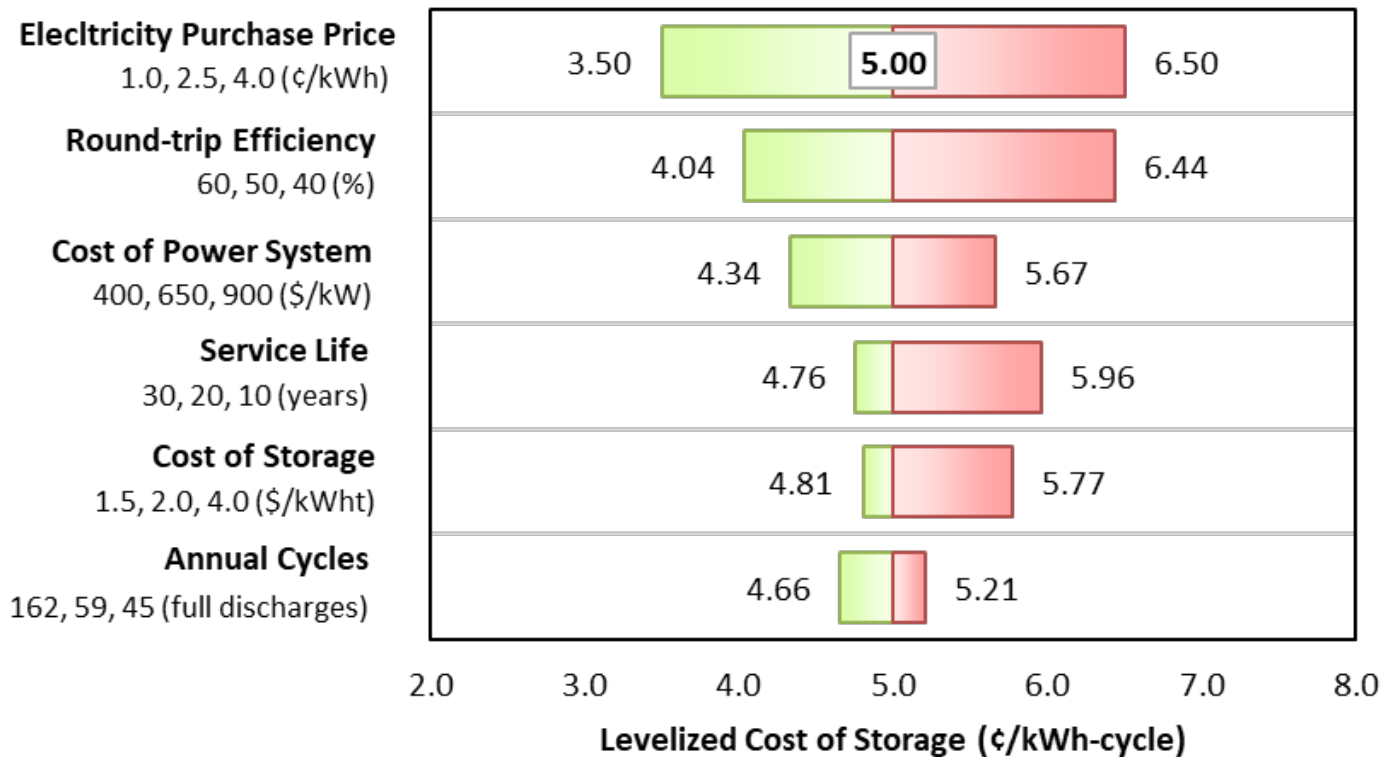

ENDURING technology has significant cost potentials.

Advantages of Low Cost Opportunity

- **Electricity Purchase Price**
 - 1 ¢/kWh – Certain curtailment amounting to a low average charging price.
 - 4 ¢/kWh – Implementing renewable electricity without discounts.
- **Round-trip Efficiency**
 - 60% – Potential Carnot Battery implementation
 - 40% – Modifying coal or gas plants.
- **Cost of Power System**
 - 400 \$/kW – Leveraging retired fossil plant or Carnot Battery.
 - 900 \$/kW – New plant adapted from a GTCC system.
- **Service Life**
 - 30 years – typical life for a thermal power plant.
 - 10 years – typical life for chemical battery.
- **Cost of Storage**
 - 1.5 \$/kWh – Use of future automated construction and 3D printing concrete silo.
 - 4.0 \$/kWh – Initial, small capacity unit.
- **Annual Cycles (Arbitrage/LDES)**
 - 162 cycles (*25-hour duration*) – Mix of daily arbitrage and DAYS storage.
 - 45 cycles (*100-hour duration*) – Serving long duration DAYS storage.

Comparison of Storage Technologies

	ENDURING TES System*	Traditional CAES**	Pumped Hydro**	Li-Ion Battery**
Size (MW)	50-400	150-500+	>100	1-100
Duration (hours)	>6 to 100	>6	>6	1 - 4
Round-Trip Efficiency	50-70% ¹	30-40%	70-85%	85%
Life cycle (cycles)	>20,000	>20,000	>20,000	5,000
Power system cost (\$/kW)	500-1,100 ²	\$1,500-\$2,500+	>\$600 - \$2,500	\$700–1,662***
Storage cost (\$/kWh)	~2\$/kWh ³	\$150-\$250+	>\$34 ⁴	\$300***
Siting Flexibility	High	Low (cavern, emissions)	Low	High

* Preliminary estimation of the EDURING system cost with the numbered assumptions (1-3).

** Based on Hydrostor brochure (<https://www.hydrostor.ca/>).

*** Li-ion costs based on Lazard LCOS v5.0, 2019.

1. Depending on power cycle: 50% for Brayton combined cycle based on GTCC, 70% based on emerging pumped thermal energy storage.

2. Low side power system cost leverages infrastructure and equipment from a retired fossil-fueled plant.

3. Approximate electric storage cost converted from thermal storage cost.

4. Estimated from Bath County PSH https://en.wikipedia.org/wiki/Bath_County_Pumped_Storage_Station, assuming turbine cost \$1000/kW, in 2019 dollars.

The ENDURING technology is competitive over other storage methods.

Conclusions

- The ENDRUING TES can integrate with various power cycles that support various power generations from converting existing thermal power plant, using existing turbine system, to integrating emerging Carnot Batteries.
- The ENDURING TES provides both hot and cold storage coupled to Carnot Batteries for high efficiency, low cost, and large capacity energy storage.
- EDURING project shows high performance and favorable cost with verified storage material stability and key component feasibility.
- The ENDURING system can transform a traditional thermal power plant into a storage facility to leverage the infrastructure and power generation for low capital cost and potentially high economic returns.
- The ENDURING TES can be sited anywhere and is competitive over batteries, pumped storage hydropower, or compressed air energy storage.

Thank you



Zhiwen Ma, 303-275-3784

Email: Zhiwen.ma@nrel.gov

- ❑ Funding support from U.S. DOE ARPA-E is acknowledged
- ❑ <https://www.frontiersin.org/research-topics/10251/long-duration-and-long-term-energy-storage-for-renewable-integration>

Questions?

www.nrel.gov

Back up slides

- Particle TES for sCO₂ power cycle in Gen3 CSP
- Brayton combined cycle efficiency with respect to turbine inlet temperature.
- Technoeconomic analysis of levelized cost of storage as defined in ARPA-E DAYS program.

Roundtrip Efficiency — a Key Parameter for Energy Storage

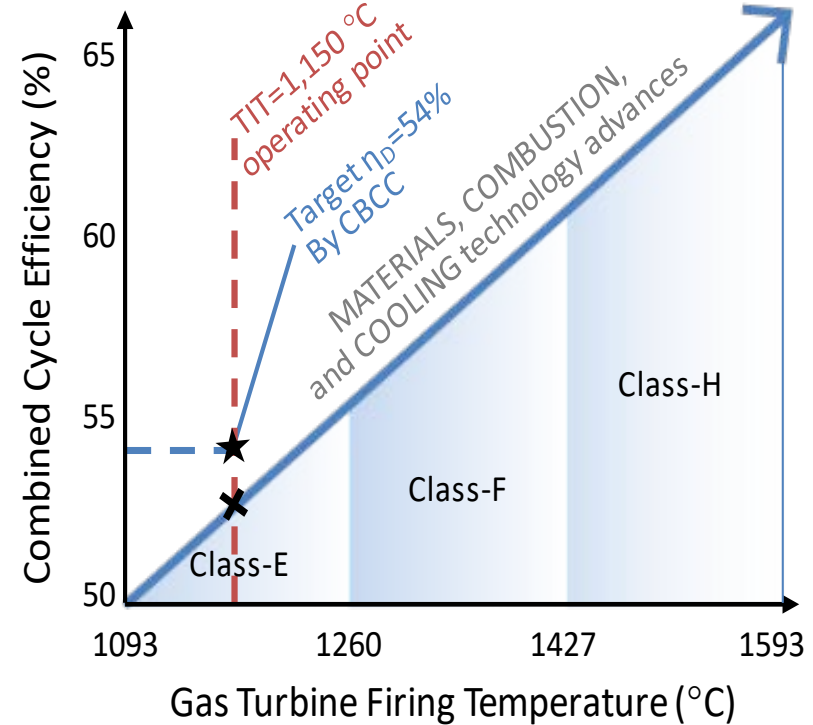
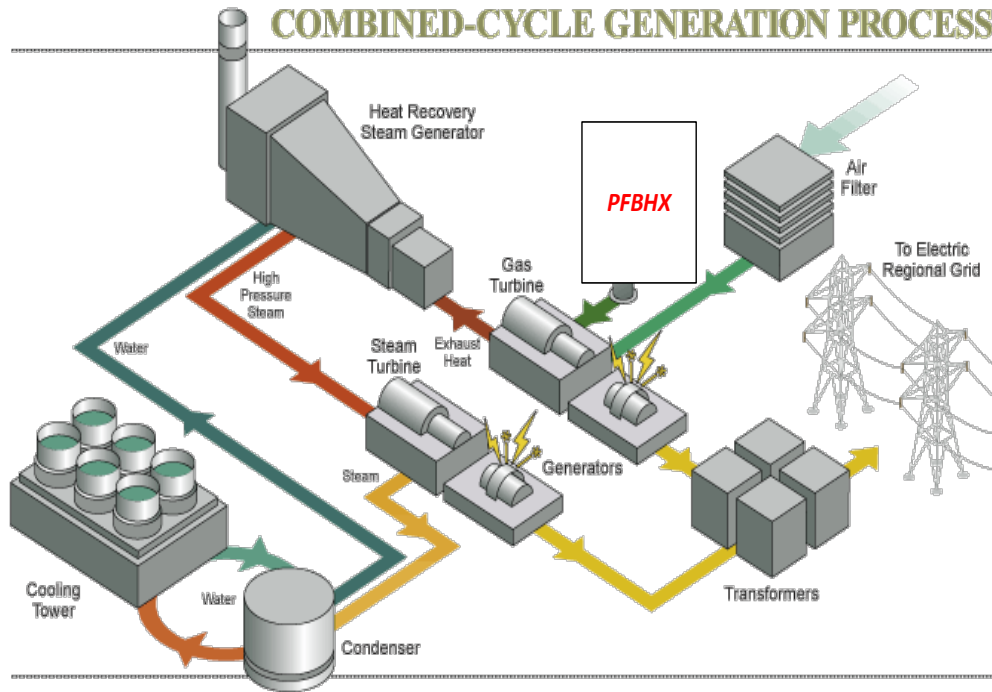

Adapting a commercial Gas turbine combined cycle provides quick market entry without waiting for the development of a power system.

LDES Economic Analysis Method

Levelized cost of storage (LCOS) as used in ARPA-E DAYS program:

$$LCOS\left(\frac{\text{¢}}{\text{kWh}}\right) = \left[\left(\frac{1}{\eta_{RTE}} - 1 \right) P_c \sum_{t=1}^T \frac{n_c(t)}{(1+r)^t} + \sum_{t=1}^T \frac{O\&M(t)}{(1+r)^t} + \left(\frac{C_E}{\eta_D} + \frac{C_P}{d} \right) \right] \cdot \left[\sum_{t=1}^T \frac{n_c(t)}{(1+r)^t} \right]^{-1}$$

Variable names and baseline input parameters:

Variables	Value	Units	Descriptions
$\eta_{RTE} =$	0.500	-	AC system round-trip efficiency (at rated power)
$P_c =$	2.5	¢/kWh	Input electricity price during charging
$T =$	20	years	System service life
$O\&M_t =$	0.00171	\$/kWh	Combination of fixed/var. operations/maintenance costs
$C_E =$	2	\$/kWh	Capital cost for (usable) energy-specific components
$C_P =$	650	\$/kW	Capital cost for power-specific components
$\eta_D =$	0.540	-	Power system generation efficiency (at rated power)
$d =$	75	hours	Storage duration (at rated power)
$n_c =$	59.00	cycles	Number of charge-discharge cycles for 75 hours duration
$r =$	0.1	-	Discount rate, applied to each time interval